

ARO[®]

FDA COMPLIANT SOLUTIONS

PART OF THE EXPERT SERIES LINE OF AIR OPERATED DIAPHRAGM PUMPS

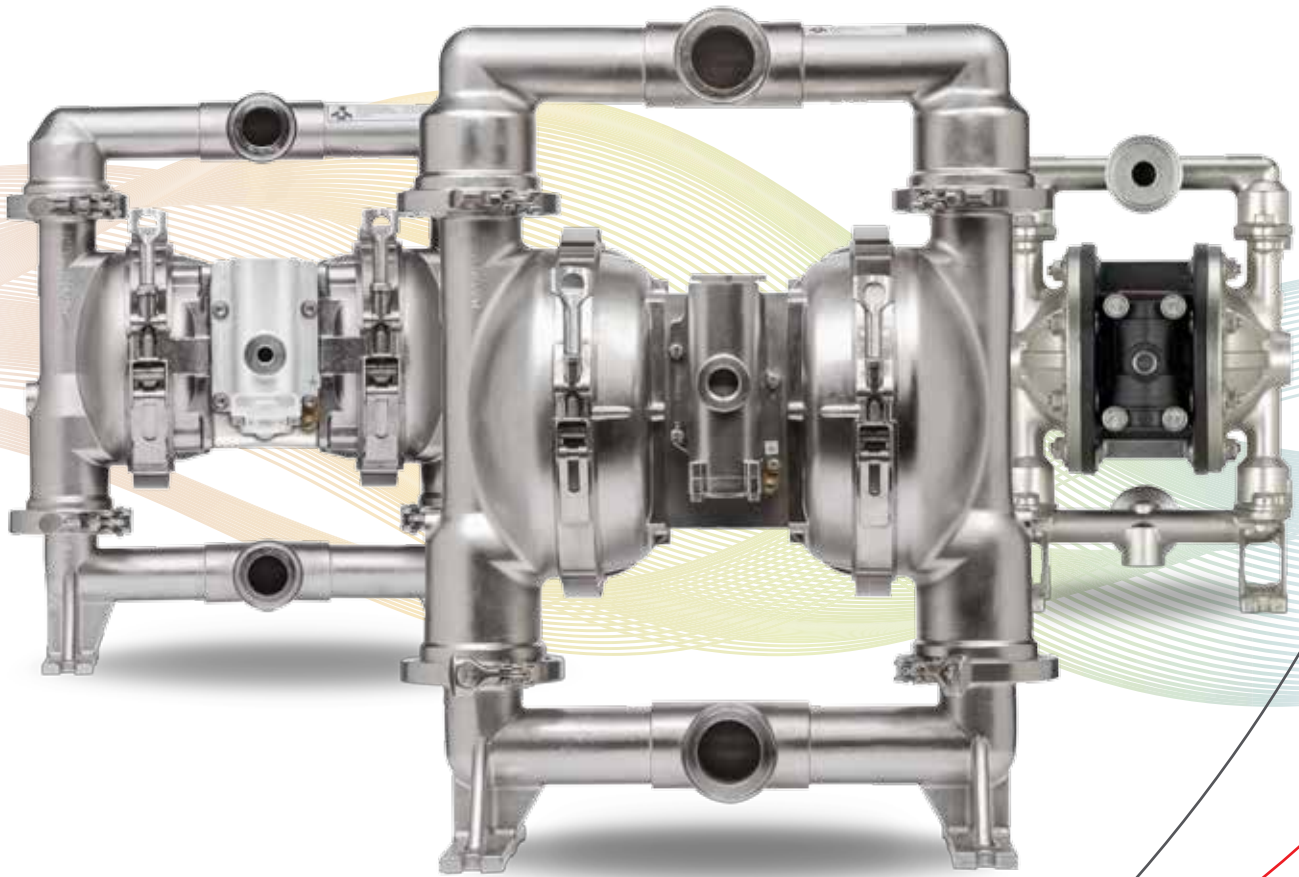



Explore our family of FDA Compliant solutions from our Expert Series line of diaphragm pumps.



Optional polypropylene center body shown

ARO® is a worldwide manufacturer of fluid management products that are skillfully engineered to deliver performance and serviceability, allowing success to flow freely in our customers' businesses. That's why ARO® is fluid intelligence—the smart choice in fluid management products for industrial operations. With over an 85-year legacy of premier product performance and service excellence, ARO® provides fluid management equipment for customers and industries around the globe.

ARO's FDA-compliant pumps, a part of our Expert Series (EXP) line, are designed to transfer fluid for the food and beverage industries efficiently and safely. Our pumps typically yield 20 to 30 percent better flow rates than other products available on the market, ensuring the material is transferred carefully. Since every ounce of fluid is treated gently, the shelf life is often extended and product quality maintained.

All ARO® EXP pumps feature:

- ▶ Patented "Unstallable" unbalanced air valve design which avoids stalling issues associated with other pumps.
- ▶ Exhaust valves that divert cold exhaust air from ice-prone components, which prevents freezing and downtime.
- ▶ Ability to pass even large shear-sensitive solids without degradation or heat build-up.
- ▶ The ability to run dry (eliminating the risk of pump damage).
- ▶ Gentle pumping action will not froth or separate fluid, improving end-product quality.



Markets and Applications

ARO® FDA compliant diaphragm pumps deliver safety and quality, as well as industry leading total cost of ownership. By combining the rugged reliability of our EXP pump design with the capacity to handle high volume transfer and dispensing applications, ARO® pumps enable you to produce more for your customers.

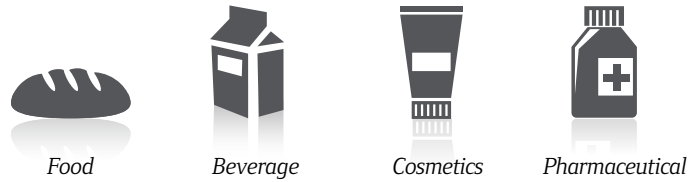

Certification: ARO® FDA Compliant pumps are engineered to meet the highest standards and requirements in the industry including: CE, ATEX, 1935/2004/EC and FDA CFR 21.177



Transfer and Batching

- Abrasive Media and Solids
- Acids, Alcohols, Caustics and Solvents
- Beverages
- Health Products
- Personal Care Products
- Pet Food
- Purees and Sauces

Receiving and Unloading

- Additives
- Chemicals
- Ingredients

Waste Water Handling (Packing)

Filter Press Feed

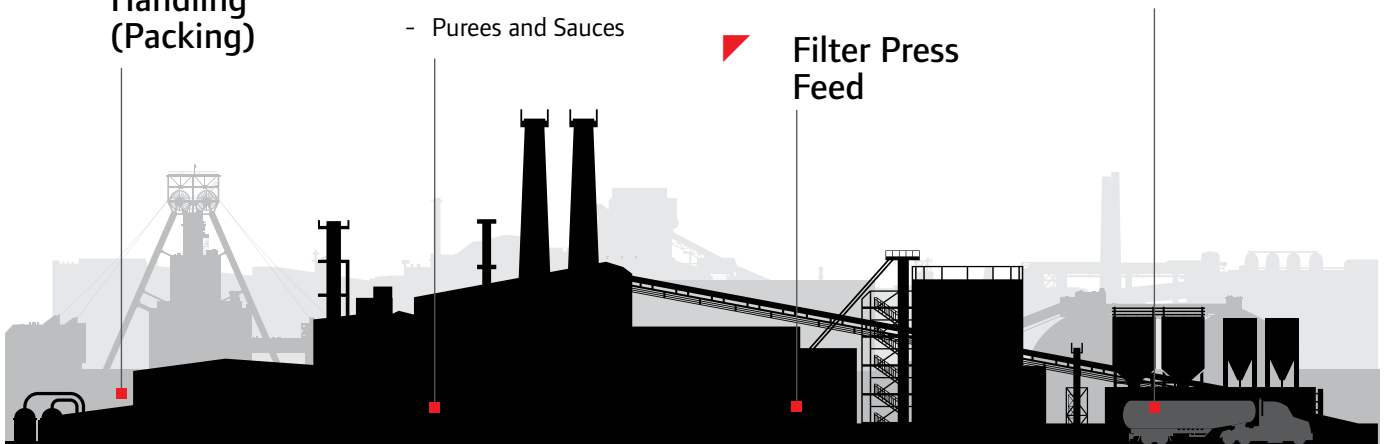

Our SD line features the Quick Knock Down (QKD) compression clamp system to facilitate easier cleaning, service, and maintenance.

➤ EXPert Series (EXP) pump design

Industry leading total cost of operation, better flow rates and higher reliability

- As an expansion of the EXP Series of dual diaphragm pumps, ARO® now offers plant managers and maintenance engineers a reliable choice for sanitary applications.

➤ Compression clamp band design

Faster cleaning, service, and maintenance

- Quick knock down (QKD) design facilitates rapid disassembly (and re-assembly) of components for inspection and maintenance—in place or out of place—and right back into service.

➤ Center bodies available in stainless steel or Polypropylene

- Stainless center bodies: Provide durable/reliable construction compliant with FDA environments.
- Polypropylene Center Bodies: Lighter and chemically compatible for the most caustic environments.

NEW!

➤ Flow-rate optimized

Better overall performance, low material shear

- ARO® EXP Series design yields 20-30% better flow rate than competitors and ensures the material is transferred unharmed.

➤ Electropolish stainless-steel 316L construction

FDA compliance and high temperature capability

- FDA compliant materials help ensure product purity and easy clean out. Exclusive 316L ball valve permits higher temperature operation.

➤ Optional electronic interface capability

Electronic interface quickly integrates with PC or PLC systems, or the ARO Controller helping to reduce waste and increase productivity

NEW!

➤ Optional Single piece composite PTFE diaphragms

- Minimizes the number of collection points for fluid being pumped
- Speeds disassembly, cleaning and reassembly

NEW!

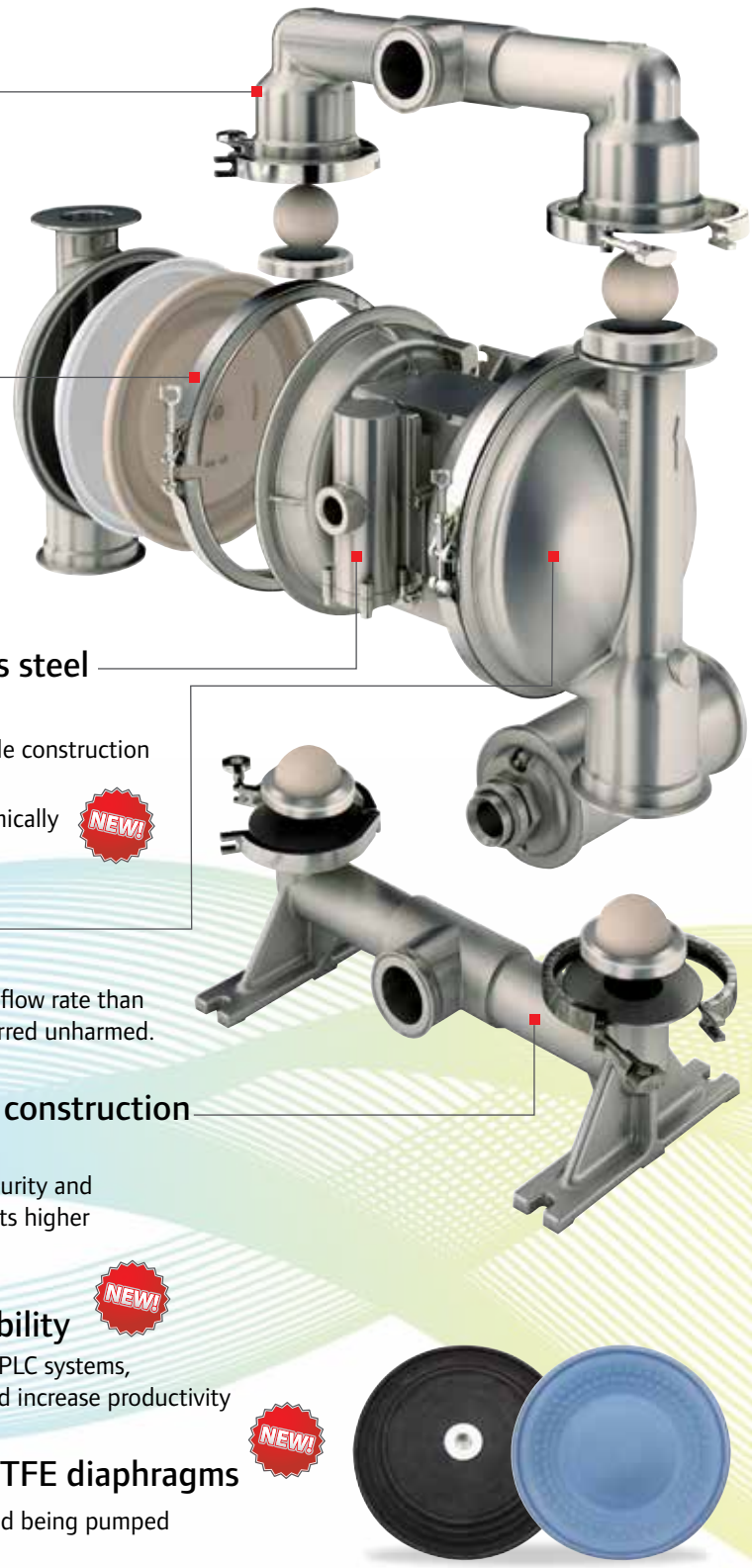

SD Series Diaphragm Pumps

Our factory-installed options let you customize your ARO® Sanitary pump to your specific application needs for cost-effective, factory control and worry-free integration. Quick knock down (QKD) design allows for quick inspection and maintenance—and then right back into service.

Additional technical information can found at AROzone.com or contact technical support at arotechsupport@irco.com

ARO® can be consulted upon request for custom FDA powder pump applications



Operating Data	SD10X-CSS-SXX-A 1" Pump	SD20X-CSS-SXX-A 2" Pump
Startup Pressure PSI (bar)	25 (1.723)	25 (1.723)
Dry suction lift ft. H2O (m)	16.49 (5.02)	18.25 (5.56)
Wet suction lift ft. H2O (m)	31.4 (9.57)	31.4 (9.57)
Flow Rate GPM (lpm)	54 (204.4)	195 (738)
Displacement per/cycle @ 100 PSI GAL (liters)	0.258 (0.976)	1.3 (4.9)
Max. Solids Passage in. (mm)	0.125 (3.175)	0.25 (6.35)
Fluid Inlet/Outlet	1-1/2" Tri-Clamp	2-1/2" Tri-Clamp

Service Kits for SD Series Pumps

	SD10S Stainless Steel Center	SD10R Polypropylene Center	SD20S Stainless Steel Center	SD20R Polypropylene Center
Fluid Kit	637493-XX		637494-XX	
Air Section Kit	637495		637497	637497-1
Valve Block Kit	637496	637496-1	637498	637498-1

SD Series Pumps Ordering

Position	1	2		3	4	5		6	7	8			9	10
Example:	SDXX	X	-	C	S	S	-	X	X	X	-	B	X	X

1- Port Size	3- Connection	6- Seat Material	7- Ball Material	8- Diaphragm Material
SD10 1" Port	C Compression Clamp	C Hytrel	C Hytrel	C Hytrel
SD20 2" Port		K PVDF	M Medical Grade Santoprene	M Medical Grade Santoprene
2- Center Section Material	4- Wetted Parts	S 316L SS	S 316L SS	T PTFE/Santoprene
S 316 SS			T PTFE	K PTFE Composite
R White Polypropylene	5- Clamps/Hardware			
	S 304 SS			

9- Specialty Code 1 (blank if no specialty code)

A - Solenoid 120VAC	F - 24vDC NEC/CEC
B - Solenoid 12VDC	G - Solenoid 12VDC ATEX/IE Cex
C - Solenoid 240VAC	H - Solenoid 24VDC ATEX/IE Cex
D - Solenoid 24VDC	J - 120VAC NEC/CEC
E - 12vDC NEC/CEC	K - Solenoid 220VAC ATEX/IE Cex
	N - Solenoid No Coil
	O - Standard Valve Block (no solenoid)

10- Specialty Code 2 (blank if no specialty code)

E - End of Stroke Feedback + Leak Detection
F - End of Stroke Feedback
G - End of Stroke Feedback ATEX/IE Cex/ NEC/CEC
H - End of Stroke Feedback/Leak Detection ATEX/IE Cex/NEC/CEC
L - Leak Detection
M - Leak Detection ATEX/IE Cex/ NEC/CEC
O - No option

PM Series Diaphragm Pumps

Our PM Series of diaphragm pumps are also constructed of electro-polished 316 stainless steel fluid section but feature bolted construction with all stainless steel hardware.

Additional technical information can be found at AROzone.com or contact technical support at arotechsupport@irco.com



Operating Data	PM05X 1/2" Pump	PM10X 1" Pump	PM15X 1-1/2" Pump	PM20X 2" Pump	PM30X 3" Pump
Flow Rate GPM (lpm)	12.0 (45.4)	52.2 (197.6)	123 (465.6)	172 (651)	275 (1041)
Displacement per Cycle GAL (liters)	0.040 (0.15)	0.232 (0.88)	0.617 (2.34)	1.4 (5.3)	2.8 (10.6)
Air Inlet (Female)	1/4 - 18 N.P.T.	1/4 - 18 N.P.T.	1/2 - 14 N.P.T.	3/4 - 14 N.P.T.F.-1	3/4 - 14 N.P.T.
Fluid Inlet / Outlet	1-1/2" Quick Disconnect Connections	1-1/2" Quick Disconnect Connections	2" Quick Disconnect Connections	2-1/2" Quick Disconnect Connections	3" Quick Disconnect Connections
Max. Operating Pressure PSI (bar)	100 (6.9)	120 (8.3)	120 (8.3)	120 (8.3)	120 (8.3)

Service Kits for PM Series Pumps

	PM05 1/2" Pump	PM10 1" Pump	PM15 1-1/2" Pump	PM20 2" Pump	PM30 3" Pump
Fluid Kit	637427-XX	637401-XX	637375-XX	637309-XX	637303-XX
Air Kit	637428	637397	637389	637421	637421

PM Series Pumps Ordering

Position	1	2	3	4	5	6	7	8	9			
Example:	PMXX	X	-	C	S	S	-	X	X	X	-	X02

1- Series/Port Size

PM05	1/2" Port
PM10	1" Port
PM15	1-1/2" Port
PM20	2" Port
PM30	3" Port

2- Center Section Material

A	Aluminum
R	Polypropylene
S	Stainless Steel

3- Connection

C	Compression Clamp
---	-------------------

4- Wetted Parts

S	Stainless Steel
---	-----------------

5- Hardware

S	Stainless Steel
---	-----------------

6- Seat Material

A	Santoprene
S	Stainless Steel

7- Ball Material

A	Santoprene
T	PTFE

8- Diaphragm Material

A	Santoprene
M	Medical Grade Santoprene
T	PTFE/Santoprene

A02	1", 1-1/2" Ported Pumps
B02	1/2", 2" Ported Pumps
C02	3" Ported Pumps

Case Study:

Create Smooth Brews with ARO® FDA Compliant Diaphragm Pumps

The Pacific Northwest is the birthplace of the American craft brewing movement. Regional craft breweries produce between 15,000 and 6 million barrels of beer per year. These breweries are unique because they take the time to create handcrafted brews with high-quality ingredients.



In 2012, Justin Brandt founded Northwest Canning, a mobile canning operation based in Portland, Oregon, that provides packaging solutions for microbreweries and regional craft breweries throughout Oregon, Washington, and Idaho. Since its inception, Northwest Canning has experienced explosive growth, and recently switched from an electric-powered centrifugal pump to the new ARO® FDA compliant air operated diaphragm pump. As a result, Brandt estimates that on average they are experiencing a 10 to 15 percent increase in production capacity. “We had evaluated other diaphragm pumps, but they were inefficient and the air requirements were too high for some breweries,” said Brandt.

Pump selection is key to maintaining the quality of beer, and speed to market

Northwest Canning used to use an electric-powered centrifugal pump mounted in its mobile canning trailer. The centrifugal pump provided a significant increase in power, but required operation on a continuous cycle. The pump used an impeller to suck the beer in and then dispense it into the filler. If the operation had to be stopped, the impeller would continue to spin, foaming up the beer in the filler and increasing the liquid’s temperature. The constant pumping of the beer introduced more oxygen into the beer, causing foam, and ultimately killing the flavor.



In early 2015, Northwest Canning replaced the centrifugal pump with an FDA compliant air operated diaphragm pump from ARO®. ARO’s FDA-compliant SD pumps are designed to transfer fluid for the food and beverage industries efficiently and safely. These pumps typically yield 20 to 30 percent better flow rates than other products available on the market, ensuring the material is transferred carefully – a high priority for brewers and canners. Since every ounce of beer is treated gently, the shelf life is extended while maintaining the carefully crafted flavor of each brew. “A gentle canning process extends the shelf life of the canned beer while maintaining flavor quality – that makes my clients happy,” Brandt said. With the centrifugal pump, Northwest Canning filled 100 to 120 cases an hour. Using the ARO pump, they now fill 160 cases an hour. According to Brandt, “with the ARO® FDA-compliant pump, Northwest Canning is now the fastest mobile cannery on the road.” [Learn more about the ARO® FDA-compliant pump at AROzone.com/FDA](http://AROzone.com/FDA)

ARO® AUTHENTIC
ARO PARTS

Exactly built and designed by ARO®, Authentic ARO® Parts are the replacement parts you can count on to restore your ARO® equipment to the equipment's original performance and quality, while backing up your warranty.

Though a part may look like an ARO® part, unless the part carries the Authentic ARO® Parts name and was bought from one of our authorized distributors, the part does not carry the ARO® promise and runs the risk of subpar chemical, metallurgical, and mechanical properties. Don't risk the downtime. Use Authentic ARO® Parts every time.

Contact us today with any of your fluid needs.

Distributed by:

www.AROzone.com

arotechsupport@irco.com

youtube.com/aropumps

(800) 495-0276

ARO®

ARO® is a brand of Ingersoll Rand. Ingersoll Rand (NYSE:IR) advances the quality of life by creating comfortable, sustainable and efficient environments. Our people and our family of brands—including Club Car®, Ingersoll Rand®, Thermo King® and Trane®—work together to enhance the quality and comfort of air in homes and buildings; transport and protect food and perishables; and increase industrial productivity and efficiency. We are a \$13 billion global business committed to a world of sustainable progress and enduring results. For more information, visit www.ingersollrand.com.